



# **TECHNICAL SPECIFICATIONS**

## **HOME PASSENGER LIFT**

### **UH**



**APPLICATION** Lift for the vertical transport of people in buildings with reduced heights and with relatively low traffic, as for example in houses, single-family houses, buildings with up to 8 apartments and semi-detached houses.

*MODEL UHP* Capacity for 2 or 3 people, depending on the car dimensions.

*MODEL UHM* Specially indicated for wheelchair users, with appropriate car dimensions and door clear openings. Depending on the car dimensions the lift may have a capacity of 3, 4 or 5 passengers, although the preferential use is for a single passenger in a wheelchair.

**REGULATIONS** The lift complies with all the requirements of the 95/16/EC Lift Directive, by means of conformity with the EN 81-2:1998+A3:2009 harmonized standard.

**CHARACTERISTICS**

*RATED LOAD* Depending on the model:

Model	Q (kg)
UHP	225
UHM	400

*SPEED* 0.5 m/s

*STOPS* Up to 6 stops

*TRAVEL* Maximum depending on the model:

Model	R (m)
UHP	18
UHM	15

**ELECTRICAL CHARACTERISTICS** 230/400V ±5% three-phase 50/60 Hz.  
 Other voltages available as an option.  
 The consumption at full load at a 400V voltage, may reach the following value, depending on the model:

Model	I (A)
UHP	14
UHM	20

**TYPE OF DRIVE** Hydraulic, indirect action lift with a 2:1 ratio, rope suspension and single cylinder drive.

*SUSPENSION* Suspension with 3 ropes, 8 mm in diameter, with composition 6x19-FC and wires of resistance 1770 N/mm<sup>2</sup>.  
 Instantaneous safety gear of the roller type, actuated by a safety rope, 6 mm in diameter.

*CYLINDER* Single action cylinder with inner buffer (hydraulic damper), rupture valve and oil inlet in the upper or lower section of the cylinder; diameters 70, 80 or 90 mm depending on the model and travel.

*PIPPING* **Rigid**, standard supply of 6 m of rigid pipping in 22 or 35 mm diameter; if angles are required, these are not included in the supply.  
**Flexible**, double metal mesh hydraulic hoses, in diameters ¾” or 1¼” and individually tested for pressure together with the corresponding connectors; the result is marked on the hose. Available as an option.

**MACHINE**

**POWER UNIT** Two speed power unit, with valve block fulfilling all the requirements of the EN 81-2+A3 harmonized standard.  
 Oil submersible motor with rated power 4,4 kW for model UHP, and 6 or 7,7 kW for model UHM depending on the options and car dimensions. Low noise level spindle pump, with rated flowrate 55, 75 or 100 l/min depending on the diameter of the cylinder.  
 Identification and instruction faceplate included in the power unit.  
 Electric resistance for oil heating in the oil tank available as an option.

**CONTROL BOARD** Control board located inside a metal cabinet, 600x500x150 mm in size.

**MACHINE CABINET (optional)** The hydraulic unit and the control board may be installed inside a cabinet of dimensions 900x420x2120 mm. The cabinet includes a fan, as well as a light with an integrated switch and power socket.  
 Inside the cabinet but outside the control board, a board with the following elements is installed: main switch, a circuit breaker for the shaft lighting circuit, a circuit breaker for the car lighting circuit and a switch for the shaft lighting.  
 Available for up to a maximum travel of 15 meters.

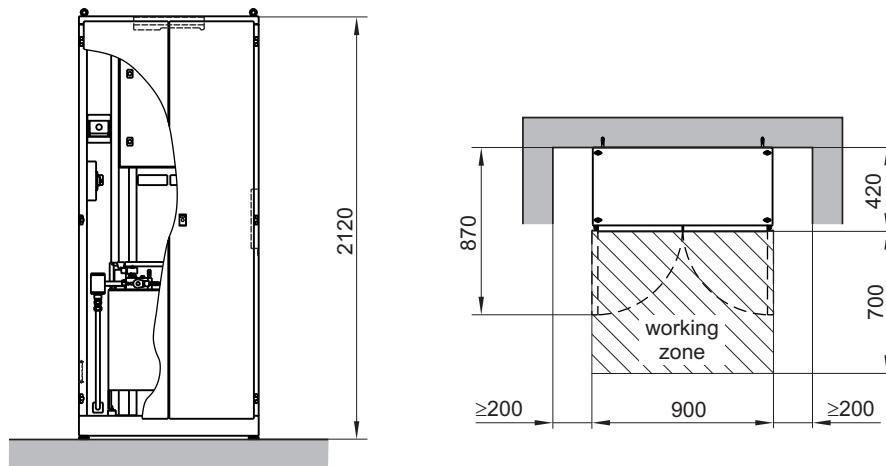

**GUIDING AND SHAFT INSTALLATION**

Both the car and the pulley head are guided on two T65 lift calibrated guides rails. Guide rails supplied in 5 m long sections, and available in 2.5 m sections as an option. Fixation of the guides to the wall with supports at least every 1500 mm. The cylinder is also designed to be fixed to the wall independently during installation. The cylinder can be supplied in two sections.

**WALL MOUNTING (standard)** All the required material for the fixation of the guides and rest of the elements to one of the walls of the shaft is supplied, using supports and anchorages for concrete. In case the wall is of hollow brick, alternative solutions for the fixation need to be implemented, such as the installation of metal profiles embedded in the wall to weld the supports, or alternatively chemical anchorages may be supplied as an option.  
 The reactions forces transmitted to the shaft are specified in the assembly instructions.

**SELF-SUPPORTING STRUCTURE (optional)** Steel structure to allow the shaft to be enclosed as required for the operation of the lift, without further brickwork being necessary. It enables the lift to be installed either attached to the wall of a courtyard or in a staircase.  
 All the required material is supplied for the fixation of the guides and the cylinder to the structure. The self-supporting structure is designed to be fixed to the floor of the pit, to the floor slabs of each landing level and to the ceiling of the shaft. Additional intermediate fixations of the guides in case of non resistant walls are not required.  
 The structure is of a modular design, made out of folded metal sheet with bolted joints that require no welding. Available enclosure wall finishings are glazed or metal sheet (solid or perforated).

**CAR**

**WALLS** Panels made of steel sheet with plastic lining as standard finishing, available in several colours and textures (see catalogue). The following colours are available as standard supply: U-35 (Green), U-60 (Gray), U-62 (Cream)  
Stainless steel panels available as an option.

**FLOOR** Rubber flooring with a circle pattern in black (standard), or light grey.  
As an option, the car may be supplied adapted for the installation of marble or granite on site. As an additional option, artificial stone in several colours can be supplied.

**CEILING** Steel sheet in white matt epoxy-polystyrene paint, as standard finish.  
False ceiling in translucent material available together with the indirect lighting option.

**PUISH BUTTON PANEL** Integrated in a column made of stainless steel sheet and installed on one of the car walls, with commands situated at an appropriate height for wheelchair users. The following elements are included:

- Send push buttons.
- Key switch push buttons (optional on request).
- Door opening push button.
- Emergency push button.
- Integrated position indicator.
- Integrated emergency lighting.
- Sound alarm push button.
- Overload indicator, with light and acoustic signalling.
- Characteristics plate in the upper part of the column with indication of load, logotype and installer reference.

**LIGHTING** With 2 50W halogen spotlights embedded in the ceiling as standard supply.  
Available as an option, indirect lighting with fluorescent tubes and a translucent false ceiling.

**TWO-WAY COMMUNICATION** (optional) The supply of an integrated intercom in the car push button pannel is possible. As an additional option, the intercom may be supplied in accordance to the EN 81-28 harmonized standard (required for the fulfillment of the lift directive).  
The supply of an additional intercom between the car and the machine room is possible, required when direct communication between the shaft and the machine room is not possible (optional).

**MISCELLANEOUS** Stainless steel skirting board.  
Available as an option, stainless steel handrail Ø40 located either on the side or on the end wall of the car. This option is recommended for use by wheelchair users.  
Available as an option, the car can be supplied prepared for the installation of a half mirror either on the side or the end wall of the car (mirror not supplied).

**DIMENSIONS** Width (A): between 700 and 1200 mm depending on door type and layout (see figures 2 and 3)  
Depth (B): between 600 and 1200 mm depending on door type and layout (see figures 2 and 3)  
Height (H): 2100 mm. Height is reduced 20 mm with the optional stone flooring, and reduced 70 mm with the indirect lighting option.  
Maximum surface according to the model:

Model	A·B (m <sup>2</sup> )
UHP	0.70
UHM	1.14

**DOOR TYPES** Automatic foldable “bus” type doors in stainless steel, with vision panel.  
 Automatic telescopic 3 leaf side opening doors, in stainless steel.  
 Enquire for other types of doors.

**ACCESSES** 1 or 2 car accesses, with possibilities for double 180° access and double 90° access. Double 90° access is only available with “bus” type foldable doors.

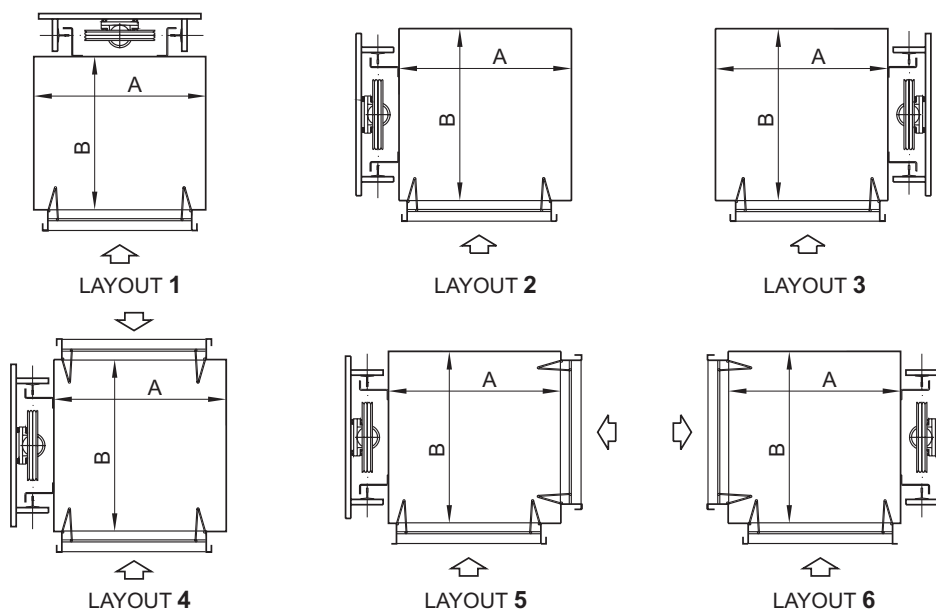

**LANDING DOORS**

**TYPES** Semiautomatic lift swing doors with vision panel, equipped with a lock actuated by the cam in the car door.  
 Telescopic 3 leaf side opening doors.  
 Enquire for other types of doors.

**FINISH** Painted in epoxy color RAL 7032 as standard finishing for both types of doors.  
 Telescopic doors available in stainless steel as an option.

**DIMENSIONS** Clear height (HL): 2000 mm  
 Clear opening (PL): 600, 650, 700, 800 mm (minimum for model UHM).

**SWING DOOR HAND**



**PUSH BUTTON PANEL**

Stainless steel plate for installation in door frame.  
 Call push button with green “car present” indicator, and red “car occupied” indicator.  
 Engraving of the logotype, name, etc, in the push button plate (optional on demand).  
 Position indicators (optional on demand).

**SHAFT DIMENSIONS**

**PIT, HEADROOM** According to travel.  
 See figure 1.

**WIDTH, DEPTH** According to car dimensions, entrance layout and door type.  
 See figures 2 and 3.

## **CONTROL**

Control with programmable logic controller.  
Simple universal control.  
Landing detection and speed change with magnetic switches.  
For lifts with automatic doors, parking with closed doors.  
Re-levelling with open doors.  
Car light timing with automatic turn-off for energy consumption reduction.

## **ELECTRICAL INSTALLATION**

Both the car and the shaft electrical installation are supplied pre-wired and with plug in terminals to connect to the electric board and to the connection box located on the car ceiling.  
The shaft lighting (optional on demand) is supplied with the lights and the pit switch pre-wired and with a plug-in connector for connection with the electric board.

## **SAFETY ELEMENTS**

Among all the safety measures and protections of the lift, we highlight the following:

- Rupture valve as a safety measure against free fall due to rupture of pipping.
- Instantaneous safety gear of the roller type actuated by safety rope as a safety measure against free fall due to breakage in the suspension elements.
- Electric anti-creep system as a safety measure against creepage.
- Safety descent valve against uncontrolled movement of the lift according to the EN 81-2+A3 standard.
- Energy accumulation car buffers, of the non-lineal type.
- Sound alarm push button in car.
- Car intercom according to EN 81-28 (optional on request).
- Automatic rescue in case of power failure.
- Signalling of car in unlocking zone for rescue operations.
- Detection of phase inversion or loss.
- Motor protection with thermistors and oil temperature sensor.
- Machine room temperature relay (optional on request).

Figure 1. Minimum shaft dimensions in elevation

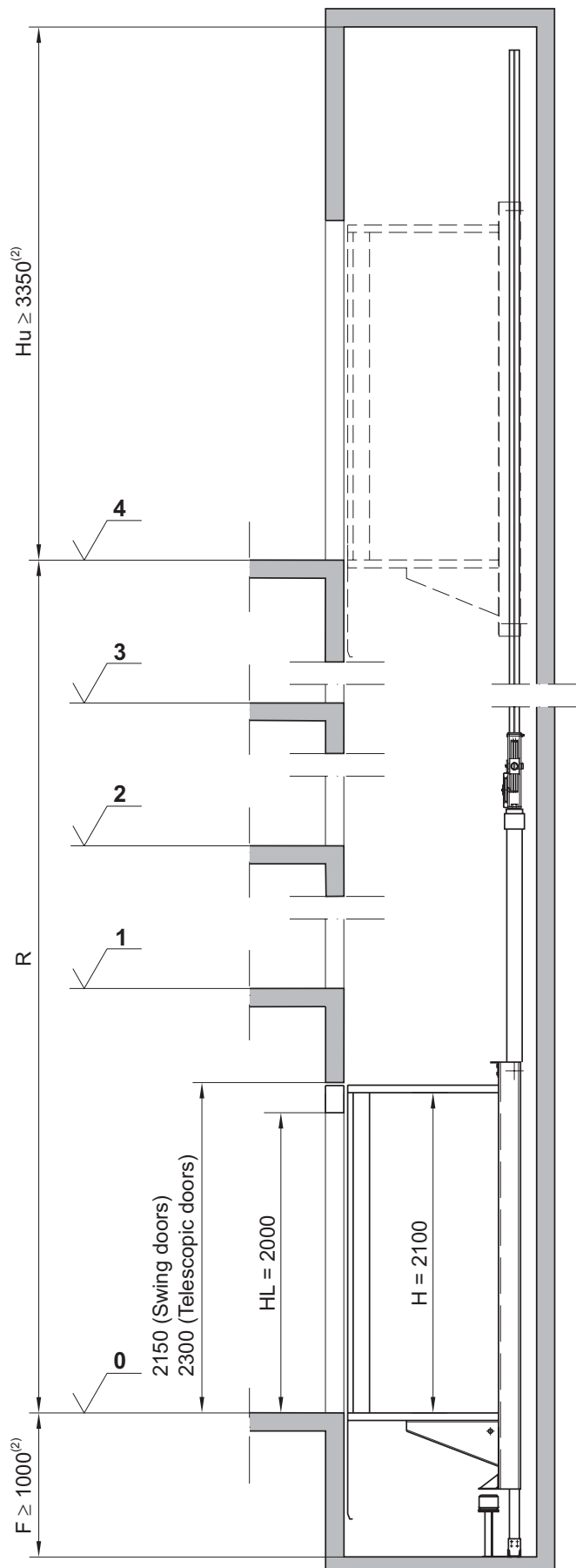

Maximum travel according to model:

Model	R (m)
UHP	18 <sup>(1)</sup>
UHM	15

<sup>(1)</sup> 15 m with the optional cabinet

- R Travel
- F Pit
- Hu Headroom
- H Car clear height
- HL Door clear height

<sup>(2)</sup> Enquire for smaller pit/headroom



Figure 2. Minimum shaft dimensions with “bus” type folding car doors

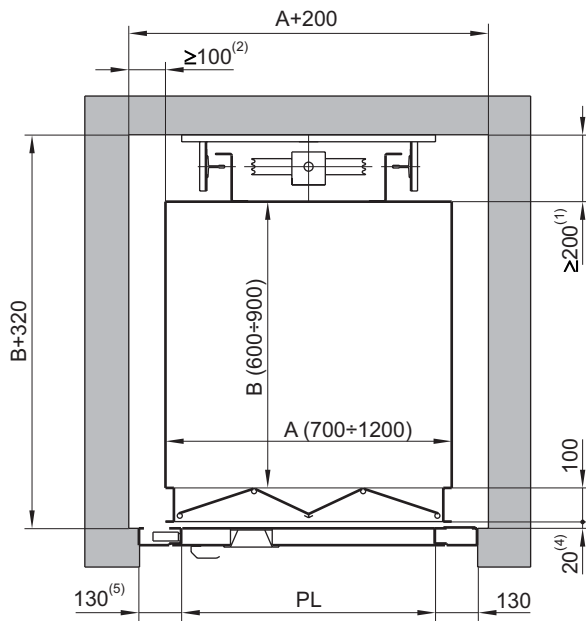

**Layout 1**

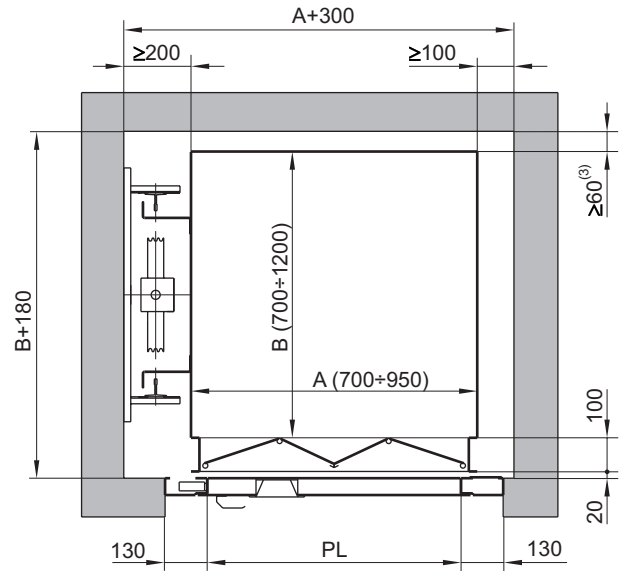

**Layout 2 (drawn)**  
**Layout 3 (symmetric)**

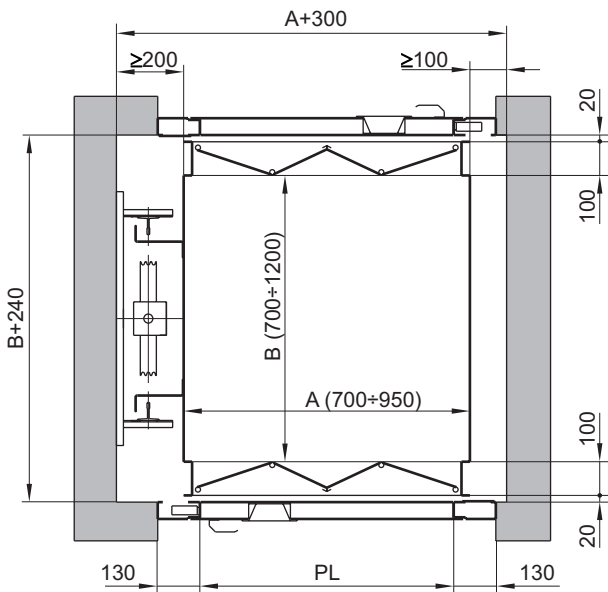

**Layout 4**

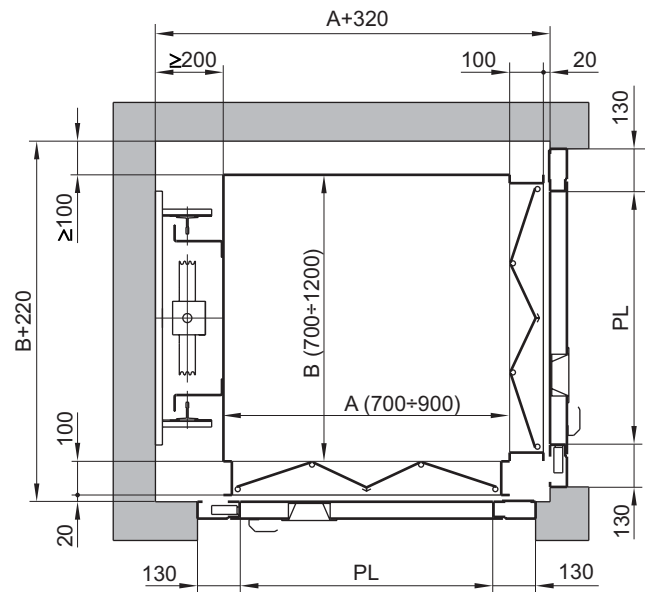

**Layout 5 (drawn)**  
**Layout 6 (symmetric)**

A Car width  
 B Car depth

PL Clear opening (maximum is the car width minus 100 mm)

(1) Minimum distance for guide installation (maximum 240 mm)

(2) Minimum car-wall distance on car push button panel side

(3) Minimum car-wall distance

(4) Distance between entrance and car

(5) Frame width of the semiautomatic door

**Figure 3.** Minimum shaft dimensions with 3 leaf telescopic doors

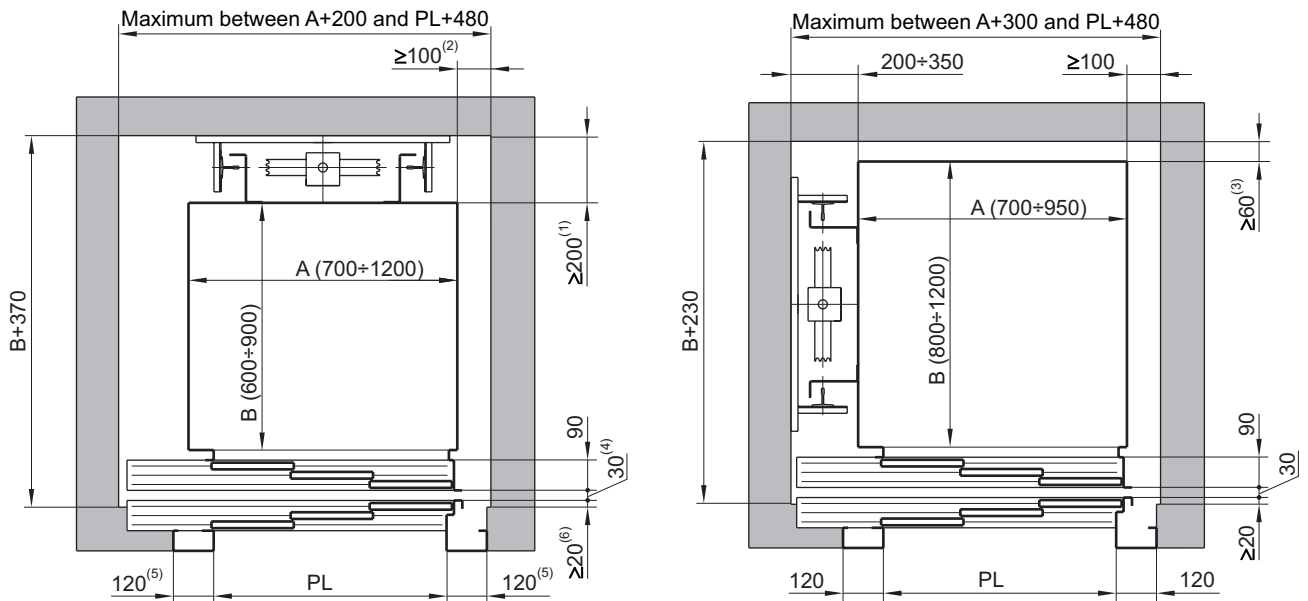

**Layout 1**  
 Left hand door (drawn)  
 Right hand door (symmetric)

**Layout 2 (drawn)**  
**Layout 3 (symmetric)**

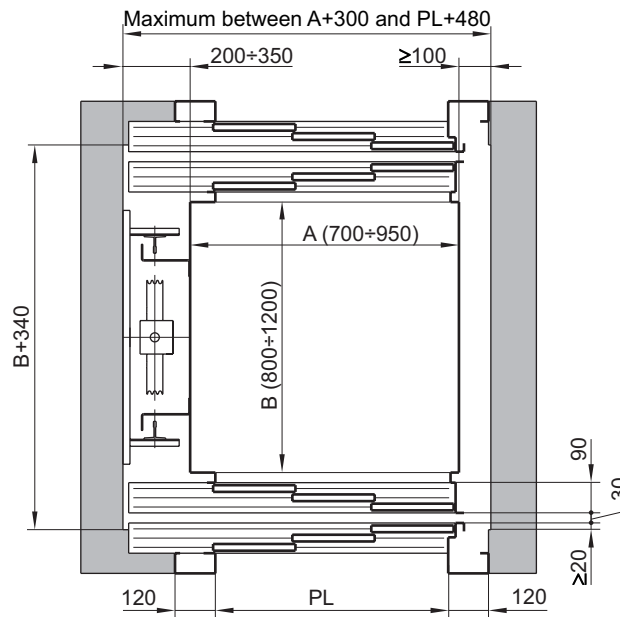

**Layout 4**

A Car width

B Car depth

PL Clear opening (maximum is the car width minus 100 mm)

(1) Distance in the guide rail space

(2) Minimum car-wall distance for wall adjacent to the entrance

(3) Minimum car-wall distance for wall on the end panel of the car

(4) Distance between entrance and car

(5) Frame width for 3 leaf telescopic door

(6) Minimum distance between landing door sill and shaft wall (maximum 75 mm)



**Hidral, S.A.**

---

P. I. PARSÍ, Calle 7, 3  
41016 SEVILLA - ESPAÑA  
Tlfn.: +34 95 451 45 00 Fax: +34 95 467 76 33  
[www.hidral.com](http://www.hidral.com)